



EAGLE ESTATE
OM INVESTMENT GROUP

VISTA
residence

+387 32 405 780
+387 61 146 967
Info@bihhome.ba
www.bihhome.ba



**EAGLE
ESTATE**
OM INVESTMENT GROUP



EAGLE ESTATE

OM INVESTMENT GROUP





Učinite sebi život ugodnijim

U srcu živopisnog naselja Brist, smještenog samo 5 minuta udaljenog od administrativnog centra grada Zenice, uzdiže se nova arhitektonska perjanica koja će obogatiti urbanu panoramu ovog grada. Predstavljamo vam budućnost modernog stanovanja – zgradu koja se sastoji od dvije elegantne građevine, spojene najsvremenijim dizajnom i visokokvalitetnim materijalima.

Svojim položajem, direktno uz glavnu saobraćajnicu, stanovnici će uživati u jednostavnom pristupu svim bitnim sadržajima grada, bez kompromisa po pitanju privatnosti i mira.

Elegancija i kvalitet

Jedna od ključnih karakteristika ovog projekta bit će prekrasan trg smješten između dvije zgrade, koji će biti oaza susreta i zajedničkih aktivnosti stanara. Ovdje će se stvarati nezaboravni trenuci druženja i opuštanja, pružajući priliku za razvijanje zajedničkog duha i povezanosti.

Posebna pažnja posvećena je položaju zgrade u odnosu na strane svijeta, te će svaki stan uživati u obilju prirodne svjetlosti i sunčevim zrakama, stvarajući ugodan i svijetao interijer. Osim toga, izvanredan pogled na okolni krajolik pružit će pravu rapsodiju boja i ugođaja, od jutarnjih zraka sunca do spektakularnih zalazaka.





EAGLE ESTATE
OM INVESTMENT GROUP

Apartmani

Ukoliko tražite spoj suvremenog luksuza, urbanog života i idilične lokacije, ova zgrada će zadovoljiti sva vaša očekivanja. Doživite budućnost stambenog prostora već danas, jer ovo će postati mjesto gdje snovi postaju stvarnost. Dobrodošli u novo poglavlje života, dobrodošli u zgradu koja će nadmašiti sva vaša očekivanja.







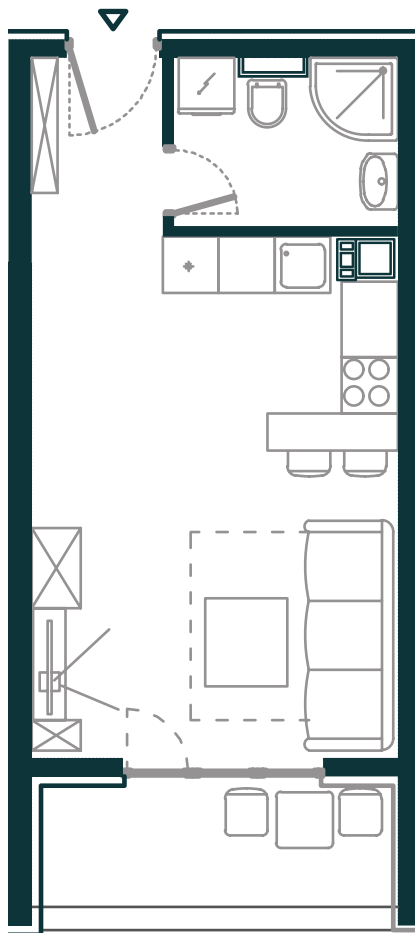

Jednosoban stan

P=32,49 m²

1. Kupatilo P=4,29 m²
2. Dnev. boravak, i kuhinja P=24,45 m²
3. Loda P=3,75 m² (5,0 X 0,75)







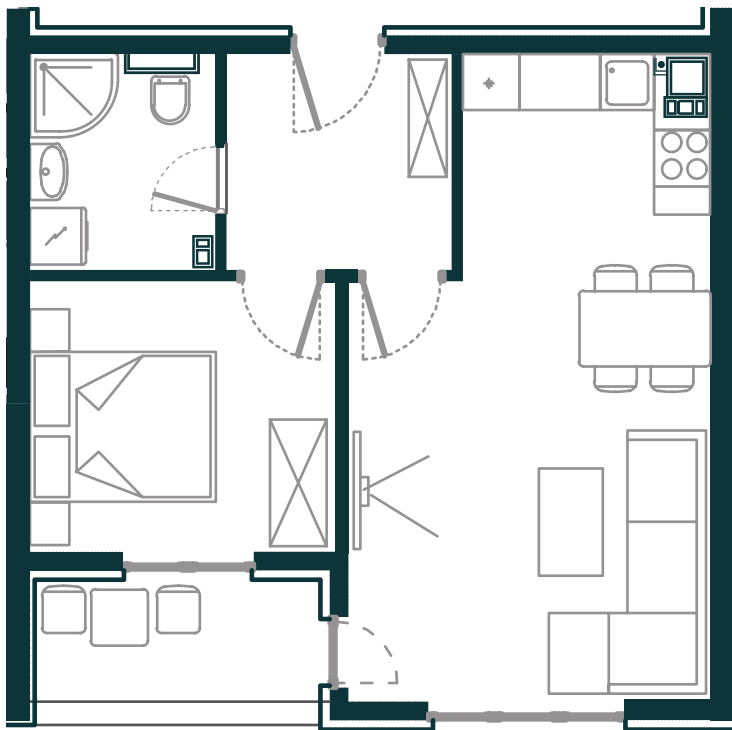

Dvosoban stan

P=46,14 M2

1. Hodnik P=5,52 m²
2. Kupatilo P=4,60 m²
3. Dnev. boravak, trpezarija i kuhinja P=23,52 m²
4. Spavaća soba P=9,50 m²
5. Loda P=3,0 m² (4,0 X 0,75)







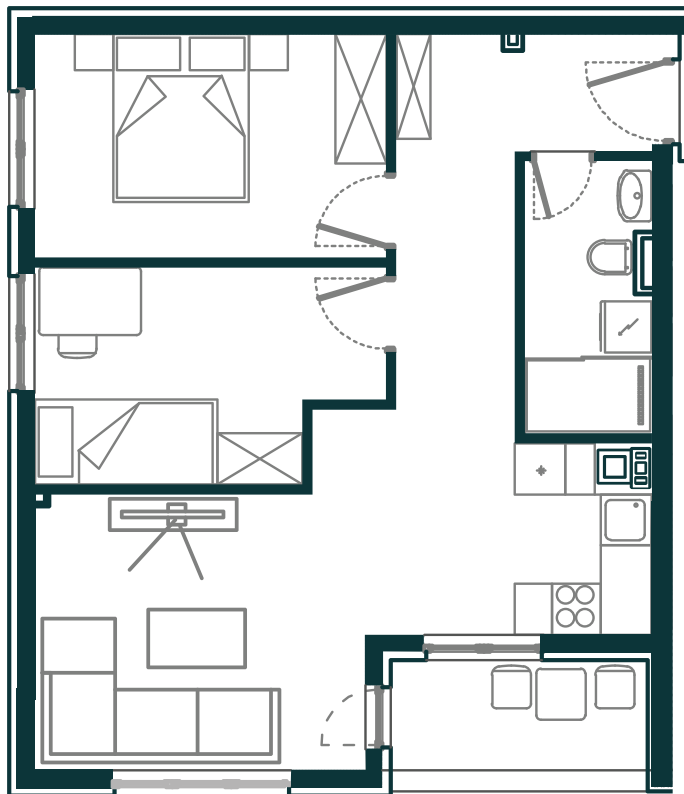

Trosoban stan

P=58,33 M2

1. Hodnik P=8,50 m²
2. Kupatilo P=4,87 m²
3. Spavaća soba 1 P=11,0 m²
4. Spavaća soba 2 P=9,60 m²
5. Dnev. boravak, trpezarija i kuhinja P=21,36 m²
6. Loda P=3,0 m² (4,0 X 0,75)







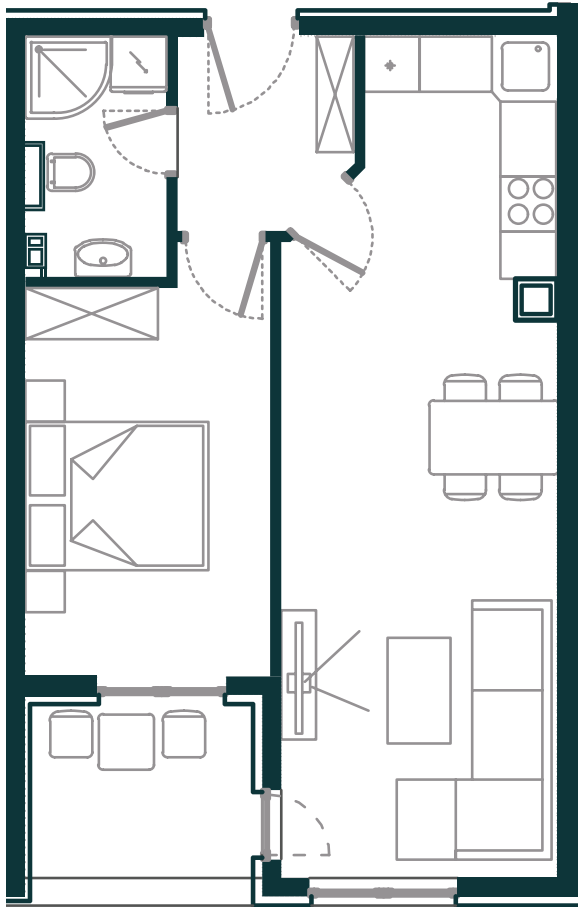

Dvosoban stan

P=46,14 M2

1. Hodnik P=5,52 m²
2. Kupatilo P=4,60 m²
3. Dnev. boravak, trpezarija i kuhinja P=23,52 m²
4. Spavaća soba P=9,50 m²
5. Loda P=3,0 m² (4,0 X 0,75)







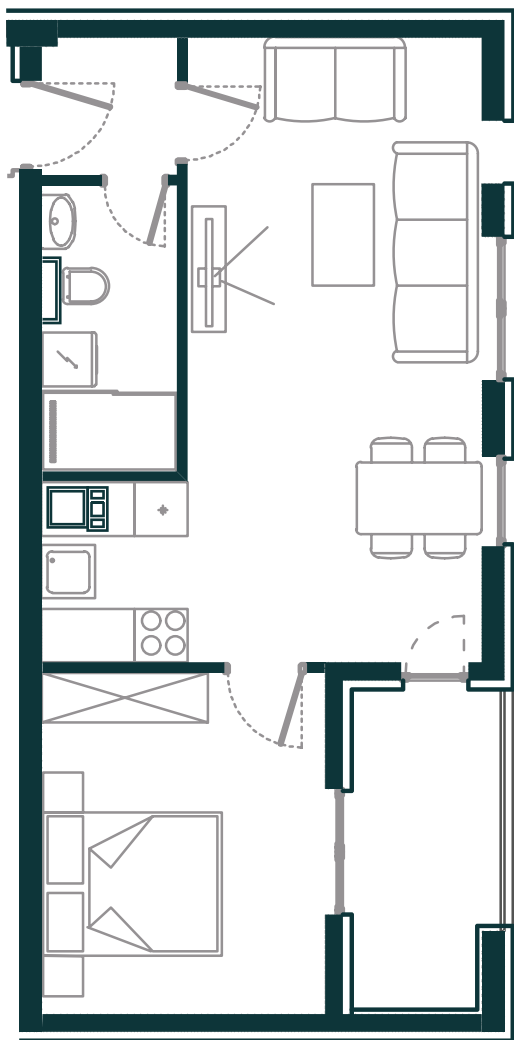

Dvosoban stan

P=46,14 M2

1. Hodnik P=5,52 m²
2. Kupatilo P=4,60 m²
3. Dnev. boravak, trpezarija i kuhinja P=23,52 m²
4. Spavaća soba P=9,50 m²
5. Loda P=3,0 m² (4,0 X 0,75)





Najsavremenija garaža

Parklift 405 dolazi na tržište sa istim inovacijama kao Parklift 450 i dodatnom prednošću. S nižom visinom plafona, omogućuje parkiranje vozila istih dimenzija kao kod Parklift 450, ali donji parking prostor je nagnut. Ova karakteristika odgovara sve većim dimenzijama automobila i potrebi za smanjenjem veličine prostora. Donja platforma je dostupna sa nagibom od 14%, dok gornja platforma ima minimalni nagib od 2%, što olakšava odvodnjavanje gornjeg parking prostora. Parklift 405 nudi jednostruki sistem za 2 automobila i dvostruki sistem za 4 automobila.





■ PARKLIFT 405-175 (295)

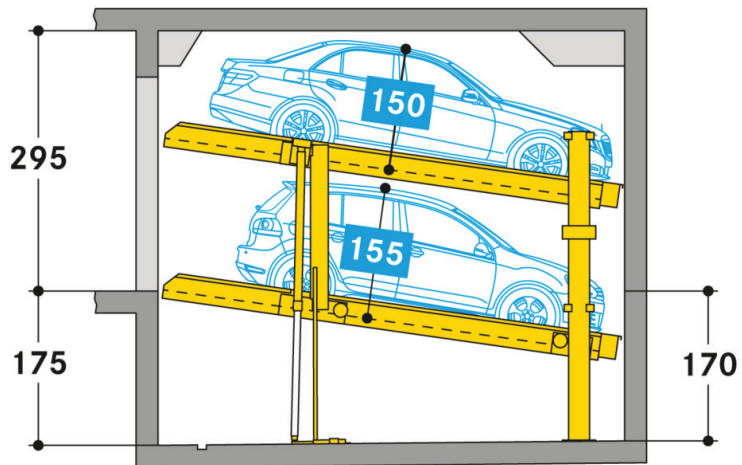

■ PARKLIFT 405-170 (300)

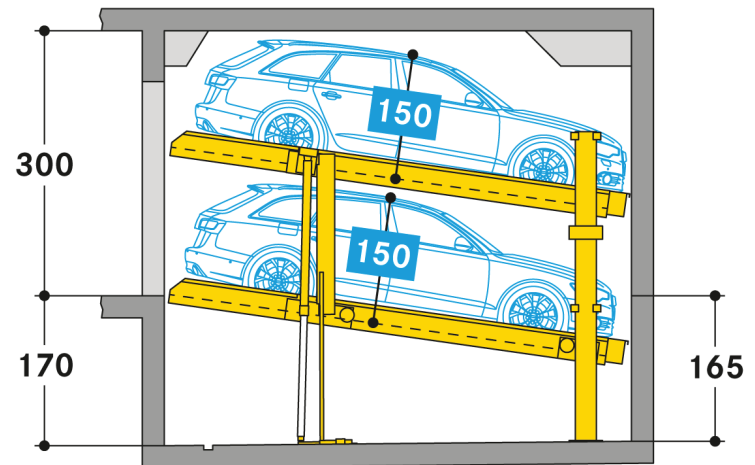

+387 32 405 780
+387 61 146 967
Info@bihhome.ba
www.bihhome.ba



**EAGLE
ESTATE**
OM INVESTMENT GROUP